

OPERATION MANUAL



FTR80 Tamping Rammer

PERFORMANCE · EFFICIENT · RELIABLE



Master sincerely thanks you for selecting the Plate Compactor Machine. For your Safety and proper operation, before you start to operate or carry out any maintenance on this equipment, **YOU MUST READ and STUDY** this manual carefully. Be sure to always keep it ready for reference.

Produced By Henan Master Machinery Co.,Ltd

Dear Customer,

Thanks for choosing Master machine.

To ensure the safety and proper use of the machine, please read the instruction book carefully before use.

Also, please fill this card and save it for warranty use.

Buyer Name		Purchase Time	
Tel		Contact Person	
Address			
Product Name	Tamping Rammer		
MODEL	FTR80		
Motor Model			
Note			

FOREWARD

- ◇ For your own safety and protection from bodily injuries, carefully read, understand and follow the safety instructions in this manual.
- ◇ Please operate and maintain your machine in accordance with the

instructions in this manual.

- ◇ Defective machine parts are to be replaced as soon as possible.
- ◇ Keep this owner's manual handy, so you can refer to it at any time.
- ◇ No part of this publication may be reproduced without written permission.
- ◇ We expressly reserve the right to technical modifications- even without express due notice - which aim at improving our machines or their safety standards.

FEATURE

FTR-80 Tamping Rammer adopts the HONDA 4-cycles engine that there are two air cleaners. The guide handle offers a highly engineered, built-in shock mount system to reduce HAV (hand-arm vibration) and improve operator comfort. Utilizing crank shaft and coupling rod configuration instead of crank and cantilever structure, which improve a great operating performance and service life. Well balanced performance reduces operator effort, non key seat design double service life of inner-cylinder body. Easy for dismounting, and low cost for maintenance.

FTR-80 Series Rammer are ideally suited for the compaction of granular, detritus, mixed and cohesive soils in confined areas, as well as apply to asphaltum detritus, concrete and clunch. This model provides reliable, comfortable use for a variety of applications such as compacting sandy oil, back fill, asphaltum, road, railroad, bridge, reservoir, dyke, courtyard, flooring and so on.

SAFETY PRECAUTIONS

1. Before starting operation, the operator has to check that all control and safety devices function properly.

2. Exhaust precautions:

- a. Never inhale exhaust gasses; They contain carbon monoxide, a colorless, odorless and extremely dangerous gas which can cause unconsciousness or death.
- b. Never operate the engine indoors or in a poorly ventilated area, such as tunnel, cave, etc.
- c. Exercise extreme care when operating the engine near people or animals.
- d. Keep the exhaust pipe free of foreign objects.

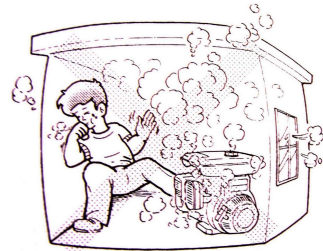

3. Refueling precautions:

- a. Be sure to stop the engine prior to refueling.
- b. Do not overfill the fuel tank.
- c. If fuel is spilt, wipe it away carefully and wait until the fuel has dried before starting the engine.
- d. After refueling, make sure that the fuel cap is secured to prevent spillage.

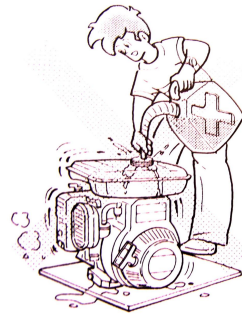

4. Fire prevention:

- a. Do not operator while smoking or near an open flame.
- b. Do not use around dry brush, twigs, cloth rags, or other flammable materials.
- c. Keep the engine at least 3 feet (1 meter) away from buildings or other structures.
- d. Keep the engine away from flam-males and other hazardous materials (trash, rags, lubrications, explosives).
- e. The muffler becomes very hot during operation and remains hot for a while after

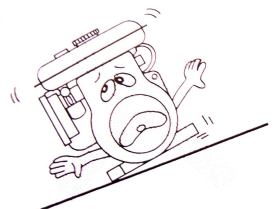

stopping the engine. Be careful not to touch the muffler while it is hot. Let the engine cool before storing it indoors.

5. The max gradient of 30° must not be exceeded when the engine working. Otherwise, the fuel will spilt and the engine oil into the cylinder, causing engine failure or other hazards.
6. Wear safety shoes, and eye protection glasses in case of trench operation where falling sand stones maybe ejected.
7. When the machine working, prohibit the operator from the machine.
8. Do not uses to compacting severity harden or hard surface, such as block, floor slab, cement block.
9. Placed a machine, we should avoid dumping, roll and fall, etc.

TRANSPORTING AND STORAGE

DANGER! Keep the engine lever off when transporting to reduce the possibility of fuel leakage. Turn the fuel valve lever to the OFF position.

1. Keep the fuel valve lever to OFF position when transporting.
2. The load-carrying capacity of the loading ramps has to be sufficient and the ramps have to be secured such that they cannot turn over. Make sure that no one be endangered by machines turning over by slipping or by moving machine parts.
3. Drain the used oil when being transported on vehicles, precautions have to be taken that vibration plates do not slip or turn over.

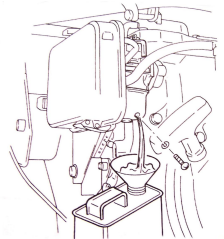

The following should be taken to prepare your FTR-80 Tamping Rammer for extended storage.

- 1、 Close fuel shut off valve.
- 2、 Store the unit in an upright position in a cool, dry, well ventilated area.
- 3、 Discharge fuel **(NO SMOKING!)**
 - a. Remove the strainer cup, place the strainer over a container and open the strainer cock to discharge fuel from the fuel tank.
 - b. Remove the carburetor float chamber bolt from the bottom and discharge fuel from the carburetor.
- 4、 Engine oil
 - a. Change the engine oil fresh oil .
 - b. Remove the spark plug, pour about 5cc of engine oil into the cylinder, slowly pull the starter handle of the recoil starter 2 or 3 times, and reinstall the spark plug.
- 5、 Clean and store
 - a. Slowly pull the recoil starter handle until resistance is felt and leave it in that position.
 - b. Clean the engines thoroughly with an oiled cloth, put the cover on, and store the engine indoors in a well-ventilated, low humidity area.

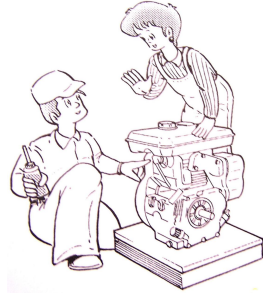

BEFORE OPERATION CHECKS

1. Check for leakage of gasoline and engine oil.

2. Check engine oil

Notice! Running the engine with a low oil level can cause engine damage.

- a. Before checking or refilling engine oil, be sure the rammer is located on a stable, level

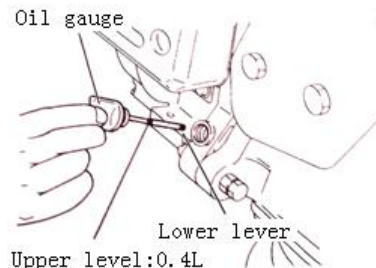

surface and stopped.

- b. Remove the filler cap/dipstick and check the oil level shown on the dipstick.
- c. If the oil level is low, fill to the edge of the oil filler hole with the recommended oil.

Oil capacity: 0.4L

SAE 10W-30 is recommended for general use. Other viscosities shown in the chart may be used when the average temperature in your area is with the recommended range.

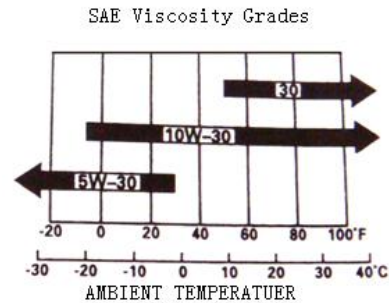

CAUTIONS! Use not depurative lubrication or 2-cycle lubrication can cause engine damage.

3. Check air cleaner

NOTICE! Operating the engine without an air filter, or with a damaged air filter, will allow dirt to enter the engine, causing rapid engine wear. This type of damage is not covered by the Distributor’s Limited Warranty.

4. Check fuel

These engines are certified to operate on unleaded gasoline. Unleaded gasoline produces fewer engine and spark plug deposits and extends exhaust system life. Never use stale or contaminated gasoline or an oil /gasoline mixture. Avoid getting dirt or water in the fuel tank. Occasionally you may hear a light “spark knock” or “pinging” (metallic rapping noise) while operating under heavy loads. This is no cause for concern. If spark knock or pinging occurs at a steady engine speed, under normal load, change brands of gasoline. If spark knock or pinging persists, see an authorized you’re servicing dealer.

DANGER!

- A. Gasoline is highly flammable and explosive.
- B. Refuel in a well-ventilated area before starting the engine. If the

engine has been running, allow it to cool. Gasoline is highly flammable and explosive.

C. Refuel carefully to avoid spilling fuel. Do not fill the fuel tank completely. Fill tank to approximately 1 inch (25mm) below the top of the fuel tank to allow for fuel expansion. It may be necessary to lower the fuel level depending on operating conditions. After refueling, tighten the fuel tank cap securely.

D. Be careful not to spill fuel when filling your fuel tank. Damage caused by spilled fuel is not covered under warranty.

E. Spilled fuel is not only a fire hazard, it causes environmental damage. Wipe up spills immediately.

F. Keep the children away from the fuel.

5. Check the oil level sight plugs on the Pipe-protective r daily to ensure the oil is half way on the site glass. Tamping Rammer capacity is **50 oz. (1600ml)**. The band of lubrication: SAE10-30.

6. Check fastening screws of protective frame and central suspension for tight fit.

STARTING THE ENGINE

Turn the STOP SWITCH clockwise to the position "1" (ON).

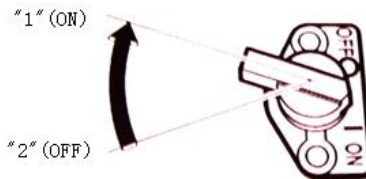

2. Open the fuel cock.

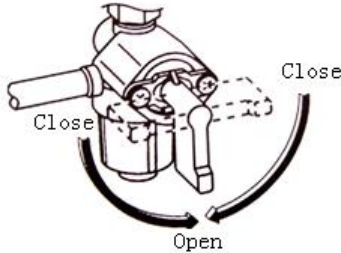

3. Close the choke lever.

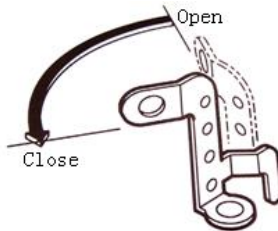

Notice! If the engine is warm or the ambient temperature is high, open the choke lever half-way, or keep it fully open. If the engine is cold or the ambient temperature is low, close the choke lever fully.

4. Set the speed throttle lever at the low speed position.

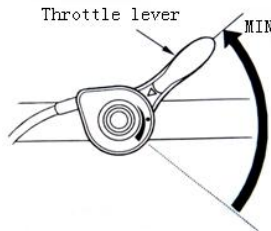

5. Pull the starter grip lightly until you feel resistance. This is the “compression” point.

Return the starter grip to its original position and pull swiftly.

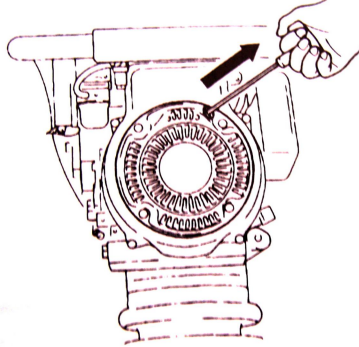

CAUTION! Do not allow the starter grip to snap back against the engine. Return it gently to prevent damage to the starter.

After starting the engine, allow the starter grip to return to its original position while still holding the starter grip.

6、 After starting the engine, gradually open choke by turning the choke lever and finally keep it fully opened.

Notice! Do not fully open the choke lever immediately when the engine is cold or the ambient temperature is low, because the engine may stop.

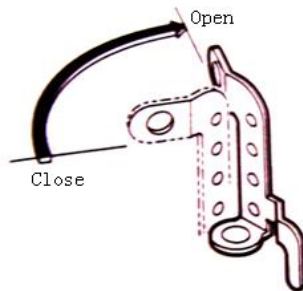

OPERATION

1. After the engine starts, set the speed throttle lever at the low speed position and warm it up without load for a few minutes. Gradually move the speed throttle lever toward the high speed position and set it at the required engine speed.

Notice! Whenever high speed operation is not required, slow the engine down (idle) by moving the speed throttle lever to save fuel and extend engine life.

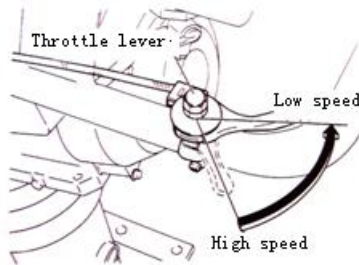

2. Through the handle guiding cause the machine to travel. The machine has the high compaction performance when the metal sheet balances on the surface. Never severity pressure or holding on the handle can damage the machine. See down fig.

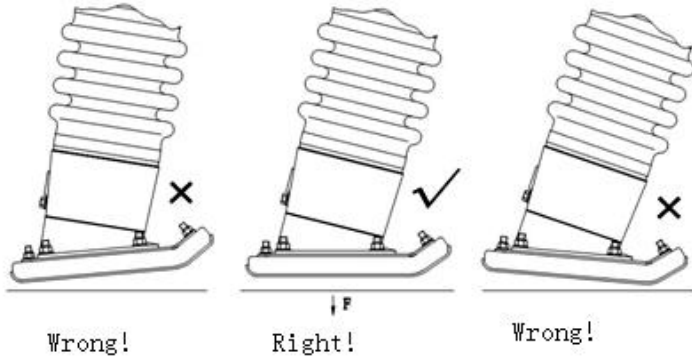

NOTICE!

- a. Turn the engine switch to the OFF position when stop working.
- b. Do not allow to the machine work on the severity harden surface.

STOP THE ENGINE

1. Set the speed throttle lever at the low speed position and allow the engine to run at low speed for 2 or 3 minutes before stopping.

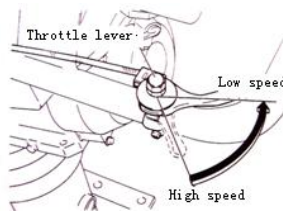

2. Turn the STOP SWITCH counter-clockwise to the position "O" (OFF).

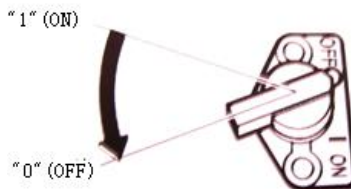

3. Close the fuel cock.

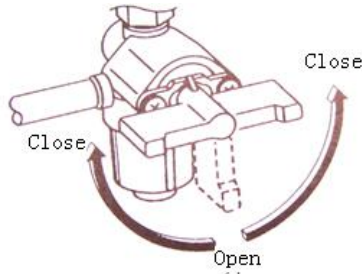

4. Pull the starter grip slowly and return the grip to its original position when resistance is felt.

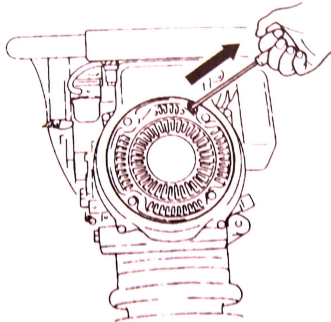

Notice! The above operation is necessary to prevent outside moist air from intruding into the combustion chamber.

PERIODIC MAINTENANCE SCHEDULE

Warning!

- a. Make sure the machine is off before you begin any maintenance or repairs.
- b. These machine should be serviced by your servicing dealer or our company service department, unless you have the proper tools and

mechanically proficient.

Warning! Please use our company's machine parts; the use of poor-quality parts may damage the machine.

Regular preventative maintenance and routine service are essential to the long life of your machine.

1. Disassembly parts:

Notice ! Please according to as follow while you need disassemble parts.

A、Disassemble four lock-nuts between foot plate and pipe-protective, and then remove foot plate.

B、Disassemble six screws (M8×25) between foot plate and pipe-protective.

C、Disassemble six screws (M12×35) among foot plate, cover and spring cylinder, then remove foot place.

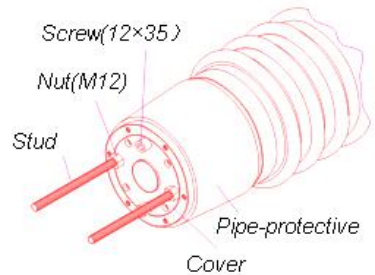

NOTICE ! Do not to remove two screws (M12×25) between cover and spring cylinder when you operate step “c”. Be careful to spring and cover bounced.

d、Install two stud (applicable types) in two disassembled screw (12×35) positions , then attach two stud with two nut(M12) (applicable types) on the cover. See right fig.

e、Remove two screw(M12×25) between cover and spring cylinder, then slowly and equably remove two nut(M12). See right fig.

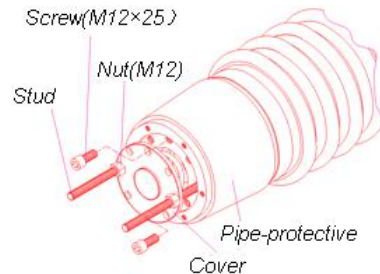

CAUTION! Keep people away from in the front two stud when remove spring, serious injury.

CAUTION! Do not allow two stud to turn when remove spring. Be careful



bounce.

2. Maintenance schedule

Engine:

		Each use	After 1 months or 20hrs	Every 3 months or 50hrs	Every 6 months or 80hrs	Every year or 200 hrs
Engine oil	Check lever	√				
	Change		√		√	
Air clean	Check	√				
	Clean			√		
	Replace					√
Spark plug	Check-clean				√	
	Replace					√
Spark arrester (applicable types)	Clean				√	
Idle speed	Check-adjust					√
Cylinder	Clean					
Combustion chamber	Clean-adjust	Every 300 hrs				
Fuel tank & filter	Clean				√	
Fuel tube	Check	Every 2 years (Replace if necessary)				

Tamping rammer:

	Each use	After month or 50 hrs	Every 6 months or 150hrs	Every year or 300 hrs
Check the oil lever sight plugs	√			
Check fastening	√	√	√	

screws				
Check for tightness engine	✓	✓	✓	
Change oil		✓		✓
Check fastening other screws	✓	✓	✓	

3. Engine oil change

Drain the used oil while the engine is warm. Warm oil drains quickly and completely.

- a. Place a suitable container below the engine to catch the used oil, and then remove the filler cap/dipstick, drain plug, and washer.

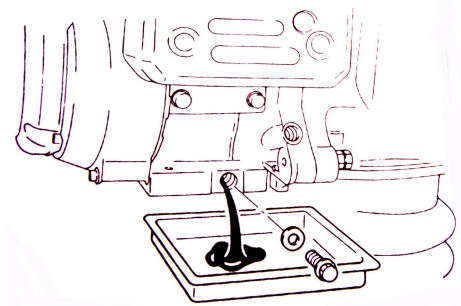

- b. Allow the used oil to drain completely, then reinstall the drain plug, washer, and tighten drain plug securely.

Notice! Please dispose of used motor oil in a manner that is compatible with the environment. We suggest you take used oil in a sealed container to your local recycling center or service station for reclamation. Do not throw it in the trash, pour it on the ground, or down a drain.

- c. With the engine in a level position, fill to the outer edge of the oil filler hole with the recommended oil.

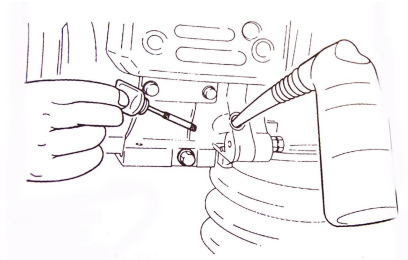

Notice! Running the engine in a low oil level can cause engine damage.

d. Screw in the filler cap/dipstick securely.

Engine oil capacity: 14oz. (0.4l)

4. Cleaning fuel

a. Inspect fuel strainer for water and dirt.

b. To remove water and dirt, close the fuel cock and remove the strainer cup.

c. After removing dirt and water, wash the strainer cup with gasoline.

Reinstall securely to prevent leakage.

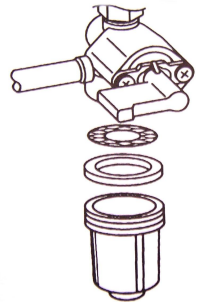

5. Cleaning air cleaner

Dirty air cleaner element will cause starting difficulty, power loss, engine malfunctions, and shorten engine life extremely.

Keep the air cleaner element clean.

Urethane foam dual structure:

a. Clean the urethane foam in the same way as described above.

b. Wash the element in kerosene or diesel fuel.

Saturate it in a mixture of 3 parts kerosene or diesel fuel and 1 part engine oil. Shake off excessive oil and reinstall.

c. If an oil bath or special air cleaner with pre-cleaner is used, clean the oil pan, fill oil to the required level or clean the dust pan.

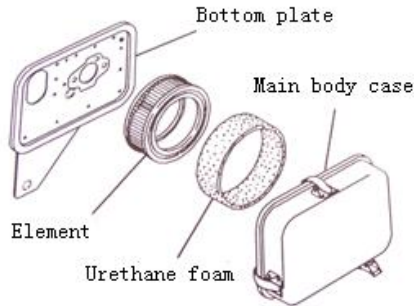

6. Spark plugs

1). Clean off carbon deposits on the spark plug electrode using a plug cleaner or wire brush.

2). Check electrode gap.

Adjust gap 0.6 mm to 0.7mm (0.02 and 0.03 inches)

3). Use a proper spark plug:

Recommended spark plugs: NGK B6ES (Robin EH12)

Warning! The recommended spark plug has the correct heat range for normal engine operating temperatures. A loose spark plug can overheat and damage the engine. Over tightening the spark plug can damage the threads in the cylinder head.

4). Check that the spark plug washer is in good condition. Install the spark plug carefully, by hand, to avoid cross-threading.

5). After the spark plug seats, tighten with a 13/16-inch spark plug wrench to compress the sealing washer. If reinstalling the used spark plug, tighten 1/8 - 1/4 turn after the spark plug seats. If installing a new spark plug, tighten 1/2 turn after the spark plug seats.

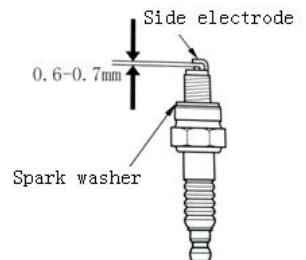

6). Attach the spark plug cap.

7. Fuel pipe replacement

Replace the fuel pipe every 2 years. When fuel leak is found replace it immediately.

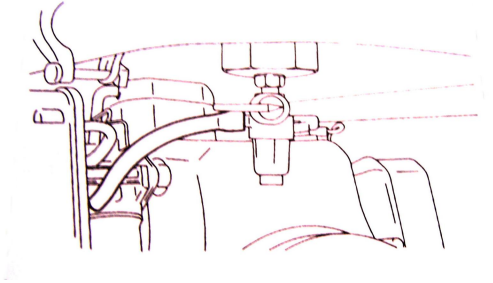

TROUBLESHOOTING

1. When engine will not start:

- a. The engine switch is OFF position.
- b. No fuel in tank
- c. Gas supply valve turned off
- d. Is there enough compression?

◇ Pull the starter grip slowly and check if resistance is felt.

◇ If littler force is required to pull the starter grip, check if the spark plug is tightened firmly.

◇ If the spark plug is loose, tighten it.

e. Is the spark plug wet with gasoline?

◇ Choke (close choke lever) and pull the starter grip five or six times. Remove the plug and check if its electrode is wet.

If the electrode is wet, fuel is well supplied to your engine.

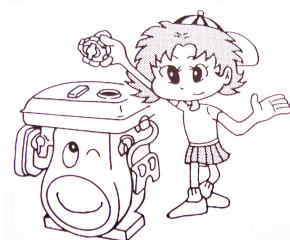

- ◇ When the electrode is dry, check where the fuel stops. (Check the fuel intake of the carburetor and fuel strainer intake.)
- ◇ In case the engine does not start with well supplied fuel, try using fresh fuel.

f. Is there a strong spark across the electrode?

Warning! Wipe out spilled fuel carefully before testing.

Place spark plug as far away from spark plug hole as possible.

Warning! Do not hold spark plug by hand while pulling recoil starter.

◇ Remove the spark plug and connect it to the plug cap.

Pull the starter grip while grounding spark plug against engine body.

- ◇ Try with a new spark plug if the spark is weak or there is no spark.
- ◇ The ignition system is faulty if there is no spark with a new spark plug.

Take your engine to your nearest Robin dealer.

2. Start but machine won't turn

- a. Clutch seized
- b. Connecting rod or spring broken
- c. Bushing seized
- d. Bearing broken

3. Start but machine won't turn ruleless

- a. Engine bolt too loosen
- b. Spring broken
- c. Engine speed ruleless
- d. Bushing severity worn

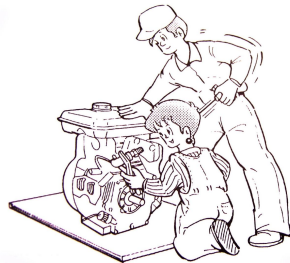

e. Copper bushing broken

4. Oil leaks

- a. Leaks positions seal worn
- b. Bellow bent or broken
- c. Leaks positions parts broken

DIAGRAME:

1.Complete Tamping Rammer:

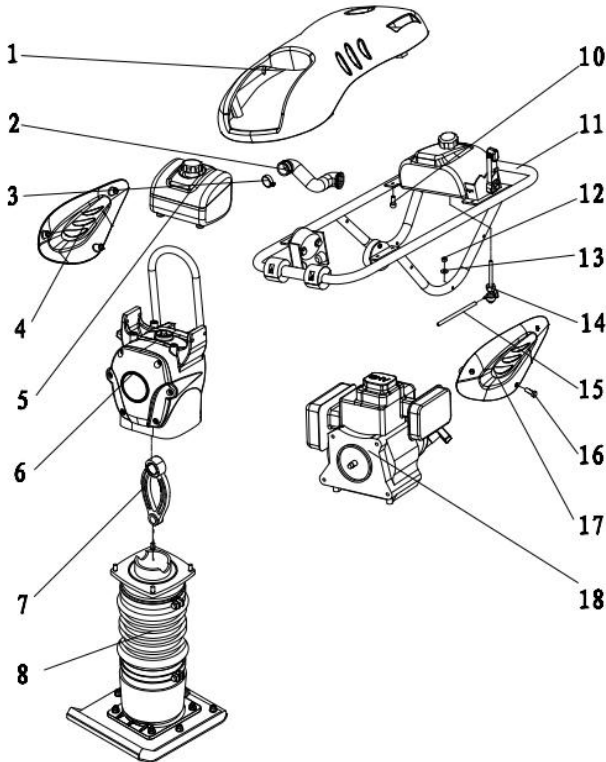

It	Pa	Drawing	Description	Qty
----	----	---------	-------------	-----

em	rt	number		
1	80	FTR80-19-01	Head Cover	1
2	10 1	FTR80-18-07	Tube	1
3	10 2	FTR80-18-06	Clamp	1
4	10 3	FTR80-24	LF Board	1
5	10 4		Air cleaner Assembly	1
6	10 5	FTR80-18	Housing-crankcase Assembly	1
7	10 6	FTR80-11	Connecting Rod	1
8	10 7		Guide Assembly	1
10	10 9	GB/T70. 1-2000	Screw (M6×20)	8
11	11 0	FTR80-16	Handle Assembly	1
12	11 1	GB/T923-76	NutM6	6
13	11 2	GB/T93-1987	Gasket (6)	6
14	11 3		Valve	1
15	11 4	FTR80-23	Hose	1

2.	16	11 5	GB/T5783-2000	Bo1t (M6×40)	6	Air
	17	11 6	FTR80-27	RH Board	1	
	18	11 7		Engine	1	

cleaner Assembly:

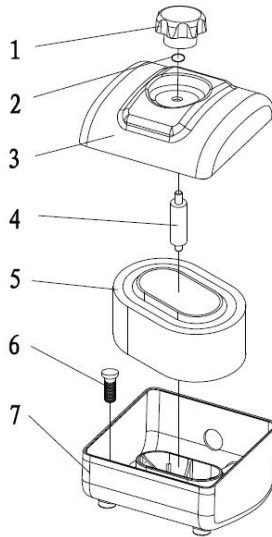

Item	Part	Drawing number	Description	Qty
1	10401	FTR80-18-01	Wave Handle	1
2	10402	GB/T1235-1976	O-Ring (11×1.9)	1
3	10403	FTR80-18-02	Cover	1
4	10404	FTR80-18-03	Pin	1
5	10405	FTR80-18-04	Air cleaner	1

6	10406	GB/T70. 1-2000	Screw (M8×35)	4
7	10407	FTR80-18-05	Box	1

3. Housing-crankcase Assembly:

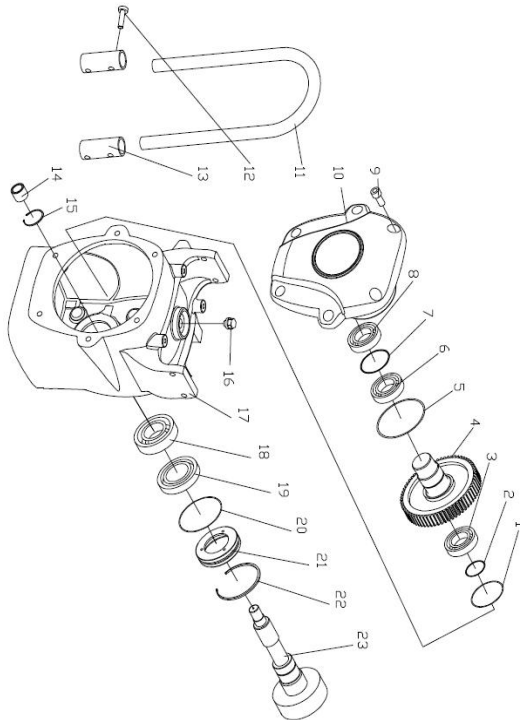

Item	Part	Drawing number	Description	Qty
1	10601	GB/T893. 1-1986	Retaining Ring (62)	1
2	10602	GB/T894. 1-1986	Retaining Ring (24)	1

3	10603	GB/T276-1994	Bearing (6305)	1
4	10604	FTR80-15	Gear-crank	1
5	10605	GB/T893.1-1986	Retaining Ring (80)	1
6	10606	GB/T276-1994	Bearing (6208)	1
7	10607	GB/T894.1-1986	Retaining Ring (38)	1
8	10608	GB/T290-1998	Bearing (HKH3520)	1
9	10609	GB/T70.1-2000	Screw (M10×25)	6
10	10610	FTR80-12	Cover	1
11	10611	FTR80-20-01	Hoist hook	1
12	10612	GB/T70.1-2000	Screw (M8×40)	4
13	10613	FTR80-20-02	Hook Bolt	2
14	10614		Bearing (7942/17)	1
15	10615	GB/T894.1-1986	Retaining Ring(A35)	1
16	10616	FTR80-17	Screw	1
17	10617	FTR80-07	Housing-Crankcase	1
18	10618	GB/T292-1964	Bearing (36207)	1
19	10619	HG4-692-67	Seal (PD40×62×12)	1
20	10620	GB/T1235-1976	O-ring (175×3.5)	1
21	10621	FTR80-14	Seal	1
22	10622	GB/T893.1-1986	Retaining Ring 75	1
23	10623	FTR80-13	Clutch Drum	1

4. Guide Assembly:

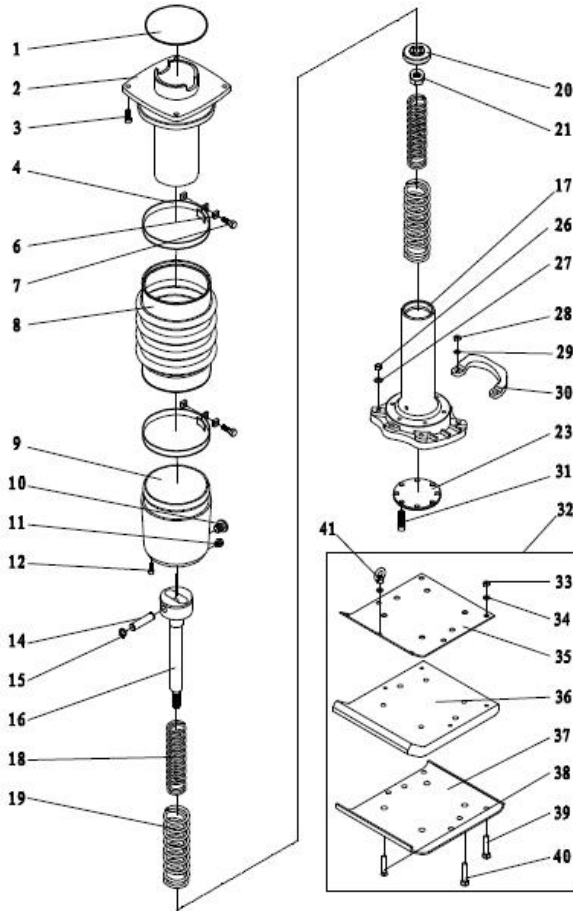

Item	Part	Drawing number	Description	Qty
1	10701	GB/T1235-1976	O-ring(105×3.1)	1
2	10702	FTR80-08	Guide Cylinder	1
3	10703	GB/T70.1-2000	Screw(M10×30)	4
4	10704	FTR80-28	Clamp	2

6	10706	GB/T39-1988	Nut (M10)	4
7	10707	GB/T5783-2000	Bolt (M10×30)	2
8	10708	FTR80-06	Bellow	1
9	10709	FTR80-01-03	Pipe-protective	1
10	10710		Oil Gauge	1
11	10711	GB/T5783-2000	Bolt (M10×16)	1
12	10712	GB/T70. 1-2000	Screw (M8×25)	6
14	10714	FTR80-10	Pin-piston Mount	1
15	10715	FTR80-05-01	Jam	2
16	10716	FTR80-05	Ram	1
17	10717	FTR80-01-04	Spring Cylinder	1
18	10718	FTR80-03	Spring	2
19	10719	FTR80-04	Spring	2
20	10720	FTR80-02	Slipper	1
21	10721	GB/T6182-2000	Locknut (M20×1.5)	1
23	10723	FTR80-01-02	Cover	1
26	10726	GB/T6182-2000	LocknutM12	4
27	10727	GB/T95-1985	Washer 12	4
28	10728	GB/T6182-2000	LocknutM12	2
29	10729	GB/T95-1985	Washer 12	2
30	10730	FTR80-01-01-01	Kit-roller	1
31	10731	GB/T70. 1-2000	ScrewM8×20	8
32	10732	FTR80-01-01	Rammer assembly	1
33	10733	GB/T6182-2000	LocknutM10	7
34	10734	GB/T95-1985	Washer 10	7
35	10735	FTR80-01-01-05	Linking piece	1

36	10736	FTR80-01-01-03	Wooden sheet	1
37	10737	FTR80-01-01-02	Metal sheet	1
38	10738	GB/T10-1988	Bolt M12×65	4
39	10739	GB/T10-1988	Bolt M10×60	7
40	10740	GB/T10-1988	Bolt M12×80	2
41	10741		Rings Nut M10	1

Handle Assembly:

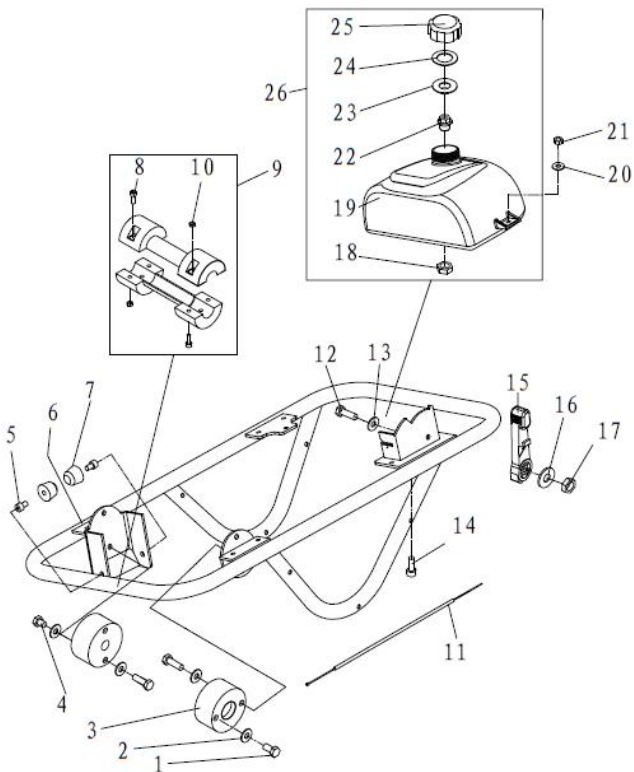

Item	Part	Drawing number	Description	Qty
1	1801	GB/T5783-2000	Bolt (M8×16)	4
2	1802	GB/T93-1987	Gasket (8)	4
3	1803	FTR80-26	Shock mount	2
4	1804	GB/T5783-2000	Screw (M8×25)	4
5	1805	GB/T70. 2-2000	Screw(M8×12)	2
6	1806	FTR80-16-01	Kit-guide handle	1
7	1807	VP1550-15-01	Rubber Block	2
8	1808	GB/T70. 1-2000	Screw (M6×16)	4
9	1809	FTR80-25	Kit-roller	1
10	11010	GB/T6183-2000	Locknut (M6)	4
11	11011		Cable-throttle	1
12	11012	GB/T5783-2000	Bolt (M8×40)	1
13	11013	GB/T5782-2000	Gasket (8)	1
14	11014	GB/T70. 1-2000	Screw (M8×20)	2
15	11015	FTR80-22-01	Timing pole	1
16	11016	FTR80-22-03	Washer	1
17	11017	GB/T6183-2000	Locknut (M8)	1
18	11018	GB/T6172. 1-2000	Nut(M16)	1
19	11019	FTR80-21-04	Oil box	1
20	11020	GB/T95-1985	Washer (8)	2
21	11021	GB/T6170-2000	Nut (M8)	2
22	11022	FTR80-21-05	Screw	1
23	11020	FTR80-21-03	Gasket-fuel Cap	1
24	11021	FTR80-21-02	Rubber Washer	1
25	11025	FTR80-21-01	Cap-fuel tank	1
26	11023		Oil box Assembly	1

7. Clutch:

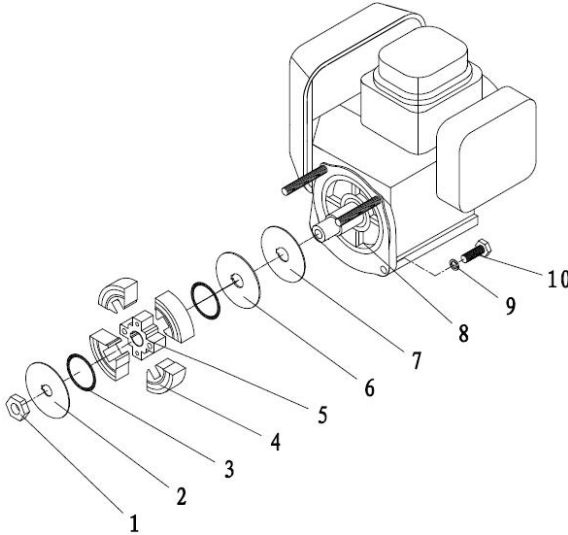

Item	Part	Drawing number	Description	Qty
1	11701		Nut-lock	1
2	11702	FTR80-09-06	Washer	1
3	11703	FTR80-09-04	Spring	4
4	11704	FTR80-09-05	Clutch	2
5	11705	FTR80-09-03	Centric	1
6	11706	FTR80-09-02	Washer II	1
7	11707	FTR80-09-01	Washer I	1
8	11708		Engine	1
9	11709	GB/T93-1987	Gasket (10)	4
10	11709	GB/T5783-2000	Screw (M10×55)	4



Henan Master Machinery Co., Ltd

Tel:(+86)17737606271 www.mastermachinerys.com
