

OPERATION MANUAL



RB16 25 32 Portable Rebar Bender

PERFORMANCE · EFFICIENT · RELIABLE

Master sincerely thanks you for selecting the Concrete Cutting Machine. For your Safety and proper operation, before you start to operate or carry out any maintenance on this equipment, **YOU MUST READ and STUDY** this manual carefully. Be sure to always keep it ready for reference.

Produced By Henan Master Machinery Co.,Ltd

**Dear Customer,
 Thanks for choosing Master machine.
 To ensure the safety and proper use of the machine, please read the instruction book carefully before use.
 Also, please fill this card and save it for warranty use.**

Buyer Name		Purchase Time	
Tel		Contact Person	
Address			
Product Name	Portable Rebar Bender		
MODEL	RB16 RB25 RB32B		
Motor Model			
Note			

Thank you very much that you have purchased the products.

This operation manual will tell you how to correctly operate and maintain your machine. Before using the machine, please read the operation manual thoroughly to guarantee the correct operation. Following the operation requirements in the operation manual will make that your machine is in the best operation state so as to extend the life of the set. For you own safety and protection injury, carefully read, understand and observe the safety instructions described in this manual.

Keep this manual or a copy of it with the machine. This machine is built with user safety in mind; however, it can present hazards if improperly operate and serviced. Follow operating instructions carefully!

GENERAL SAFETY PRECAUTIONS

USAGE

Use rebar bender on concrete re-inforcing bars only.

RESRICT USE TO DESIGNATED MATERIALS

Don't use the machine to bend very hard rebar. The hard rebar may break and will also damage the tool. Do not attempt to bend rebars. Harder, thicker or thinner than those specified (see page 5).

USE EYE PROTECTION

Wear safety goggles, safety glasses with side shields or a face shield while using bender.

PROVIDE SAFETY BARRIERS

Erect safety screens to protect co-workers from possible flying ends. Place safety screen under the rebar when working in high places.

GUARD AGAINST ELECTRIC SHOCK

To avoid possible electric shock, do not handle bender with wet hands or use bender in the rain or damp places. Be aware of all power lines, electric circuits and other hazards that may be contacted, especially those that are below the surface or otherwise hidden from view

UNPLUG TOOL

Disconnect bender from outlet while not in use and before cleaning,adjusting or servicing.Do not disconnect plug from outlet by pulling the cord.Always check that the switch lock is OFF before plugging in.

BEWARE OF ENVIRONMENT

Do not use bender in the presence of flammable materials(e.g. paint,thinner, petroleum products ,adhesives).

Do not use bender in a possibly lighted and clear of obstructions.Operator should at all times have an unobstructed view of the cutter,rebar and surrounding area.

WEAR PROPER APPAREL

Do not wear loose clothes,dangling objects or jewellery.Restrict long hair. The use of a safety-helmet and rubber soled boots is recommended.If safety gloves are worn,be especially careful that gloves does not get caught in moving parts

KEEP VISITORS AWAY

Keep all visitors at a safe distance from the work area for their own protection And to prevent distraction of the operator.

MAINTAIN BENDER WITH CARE

Inspect bender before each application. Keep handle dry, clean and free from oil and/or grease. Keep housing and piston free of dirt and iron filings. Check that no screws or bolts are loose or missing. Following instructions for maintenance. Inspect switch, cord, Plug and any extension cable at regular intervals.

STORE CAREFULLY

When not in use, store bender and accessories in a dry place where they can't be accessed by unauthorized persons.

PARTS AND SPECIFICATIONS OF NRB-32

1. Handle
2. Switch
3. Mode control lever
4. Oil plug
5. Front handle
6. Hook
7. Roller
8. Housing
9. Motor

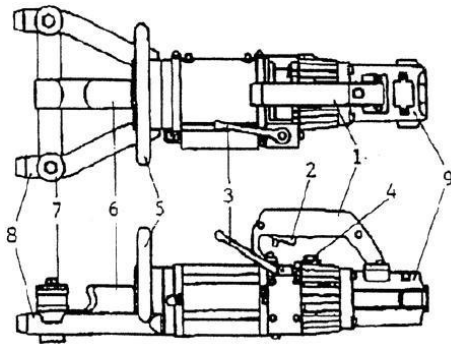

PARTS AND SPECIFICATIONS OF RB-16

- 1.Head
- 2.Bend blocks
- 3.Adjustable stopper
- 4.Side handle (detachable)
- 5.Cylinder
- 6.Oil case
- 7.Pump case
- 8.Oil-plug
- 9.Carbon brush holder
10. Carbon brush
11. Switch
12. Plastic house
13. Motor
14. Switch
15. bending piston

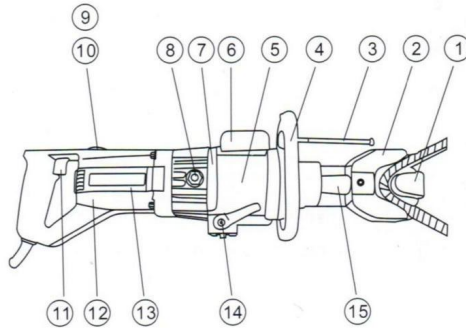

Model	NRB-32	NRB-25	NRB-22	RB-16
Voltage + 5%	□100/115V □220-240V AC only			
Wattage	1600 W	1500W	1200W	900W
Dimensions	560*260*200	560*170*220 mm	580*170*210 mm	600*170*200 mm
Weight	24 Kg	16 Kg	16KG	15KG
Max.rebar diameter	32 mm	25mm	22mm	16mm
Min.rebar diameter	4mm	4mm	4mm	4mm
Max.rebar hardness	Tensile strength 650N/mm ²			
Bending speed	5.0 -8.0 sec.	5.0s	4-5S	4-5s

OPERATING INSTRUCTIONS

! CAUTION: Indicates hazard that could result in minor personal injury and/or product damage.

CARE: Indicates hazard that will result in product damage. PRE-USE CHECKS

1. Check oil level.

2. Check condition of bender blocks and tightness of bender block bolts. 3. Check that the power source is appropriate to the bender

CARE: if voltage is too high, the motor will burn out. If the voltage is too Low, insufficient power will be generated. Never use DC power.

4. Check that power supply is properly earthed.

! CAUTION: Failure to earth power supply may result in electric shock to operator.

5. Check that cord is undamaged and that plug is not loose.

If an extension cable is to be used, make sure that it is undamaged and that it is the proper thickness for the length. See table below.

Cable length	110/115V	230V
	Cable size (AWG)	Nominal diameter
Up to 10m (33 ft)	16	1.0mm ²
Up to 15m (50 ft)	14	1.25mm ²
Up to 30m (100 ft)	10	1.5mm ²

6. Before plugging in, make sure that the switch lock is OFF.

WARM-UP

In cold weather, warm up unit for 30~60 seconds so that the hydraulic oil reaches the proper viscosity. Pull trigger-switch to extend piston and release when it has reached its full stroke. Repeat 15~20 times.

POINTS OF ATTENTION

1. Do not cover air vents.

CARE: If events are covered, motor will overheat and may burn out. 2. If hydraulic oil exceeds 70. (158.F) in temperature, power will drop.

Allow unit to cool before resuming operation. (Be particularly careful in summer, when the aluminum pump case heats up quicker.)

3. If a drop in power is observed and motor is unusually hot, check carbon-brushes.

OPERATION

The NRB-32 is primarily intended to straighten deformed rebar. It can of course, also be used to bend straight rebar.

To enable the unit to be used in confined spaces, there are two

operating modes: PUSH & PULL. The mode is selected by moving the mode control lever to the appropriate position.

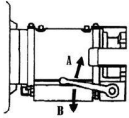

“A” for push (piston advances) and “B” for pull

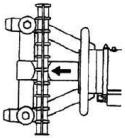

(piston retracts) in either mode, simply press the switch to move the piston

NB: The movement of the piston is limited by a safety valve. To prevent overheating, release the trigger switch when the piston has reached its travel limit.

TO PUSH

Advance or retract the piston so that the hook is in a suitable starting position. Set the mode control lever to “A” and fit the rebar as shown at the left. Pull the trigger switch until the rebar is at the desired angle.

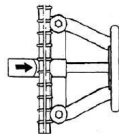

TO PULL

Set the hook in the correct starting position, make sure that the mode control lever is in the “B” position and fit the rebar as illustrated. Pull the trigger switch until the desired angle is attained.

NB: It is important that the rebar be properly fitted in the hook and against the rollers.

INTERIOR ANGLE

Since the piston stroke is limited , interior straightening/bending angle will vary according to rebar diameter and operating mode. Refer to the table below.

MAINTENANCE

CLEANING

Cleaning bender every day,preferably immediately after use.

!CAUTION: Wear gloves to protect hands from metal splinters.Do not use an air-gun:blasting with air can cause metal filings and/or dust to get into eyes and respiratory system.

1. Disconnect unit.
2. Wipe or brush away all dirt and metal filings.Pay particular attention to the lower half of the piston, where dirt is more easily accumulated.

OIL-LEVEL CHECK

As the bender is hydraulically operated,the oil-level must be checked at frequent intervals,preferably every day.Failure to maintain the oil at the proper level results in a drop in pressure and loss of bending power

!CAUTION: Hydraulic oil is highly flammable.Keep away from sparks and naked flame.Do not smoke.

!CAUTION:Hydraulic oil may cause inflammation of the eyes and skin.If ingested,it will cause diarrhoea and vomiting. In case of eye contact, rinse in clean water for at least 15 minutes And consult a physician.

In case of skin contact, wash thoroughly with soap and water. In case of ingestion, consult a physician immediately. Do not Deliberately induce vomiting.

1. Oil should be warm but not hot. Warm up unit if cold.
2. Adjust stopper and make three or four cuts, noting exactly at what point the Rebar is actually breaking.
3. Pinch a short piece of rebar, stopping just before it breaks off. Unplug unit From power source.
4. with partially severed rebar in place, turn unit over so that oil-plug is uppermost. (If unit is hot,allow to cool down.)
5. Remove oil-plug and seal-washer (packing).

!CAUTION: Never remove oil-plug when unit is hot or oil will spurt out.

6. Check that oil is level with bottom of plug hole(i.e. that pump case is full to The brim). If oil level is too low,top up with 20-weight hydraulic oil with Anti-foam and anti-abrasion properties (ISO viscosity grade VG46, e.g. Shell Oil Tellus 46, Mobil oil DTE-25 or Esso Uni power SQ46).

7. After topping up, extract air from system. Gently tilt cutter lengthwise and Return it to a level position. Top up again and tilt in the opposite direction. Repeat this process until all air has been extracted. CARE: Bender cannot function properly if oil contains air bubbles.
8. Replace seal washer (packing) and plug. Connect cutter to power source and completely sever rebar.

OIL-CHANGE

The hydraulic oil should be changed at least once a year, sooner if it appears dirty.

Unplug unit from power source. Remove oil-plug and packing. Turn bender Over and drain oil into a suitable receptacle. When oil ceases to drain out, tilt unit to rear so that oil trapped in the piston housing can run out. When housing is empty, tilt unit in the opposite direction to empty residue in the pump case.

1. With drain-hole uppermost, slowly fill the unit with fresh oil. Replace plug And lightly tighten. Connect unit to power source and advance piston two or three times. Unplug unit and remove oil-plug. Top up oil-level and replace plug.
2. Finally, follow procedure for oil-level check. (Steps 2~8.)

Note: Dispose of hydraulic oil in accordance with local regulations. Do not Pour into the sea, a river, a lake or drains.

BOLT TIGHTNESS

Once a week, or after every 500 bends, check the tightness of all bolts, especially those securing the housing to the cylinder. Loose bolts will result in a loss of power.

CARBON BRUSHES

Inspect the two carbon brushes at least once every two months,(Nominal brush life is 200 hours).

CARE: worn brushes will result in power loss, cause the motor to run hot And irreparably damage the armature's commutator.

1. Disconnect unit.

2. Unscrew both brush caps and pull out carbon

brushes. 3. Replace brushes if less than 6 cm in length